

A reliable and sufficient supply water that is clean, clear and tastes good...

Why don't we have free reign on water use?



[Home](#) > [Help](#) > [Saving water](#)

Saving water

Water in numbers:

- in the UK, the average person uses **150 litres of water a day**
- a shower can use around **49 litres of water a day**, and
- brushing your teeth with the tap on can waste **6 litres a minute**.

Wasting water is like pouring your money down the drain.

If you think not having a meter means you can use as much as you like, think again.

We're lucky here in the north of England, but clean water is not unlimited. We all need to think about how we use water, and what we can do to cut down our usage.

[Read our useful tips to find out how you can save water.](#)



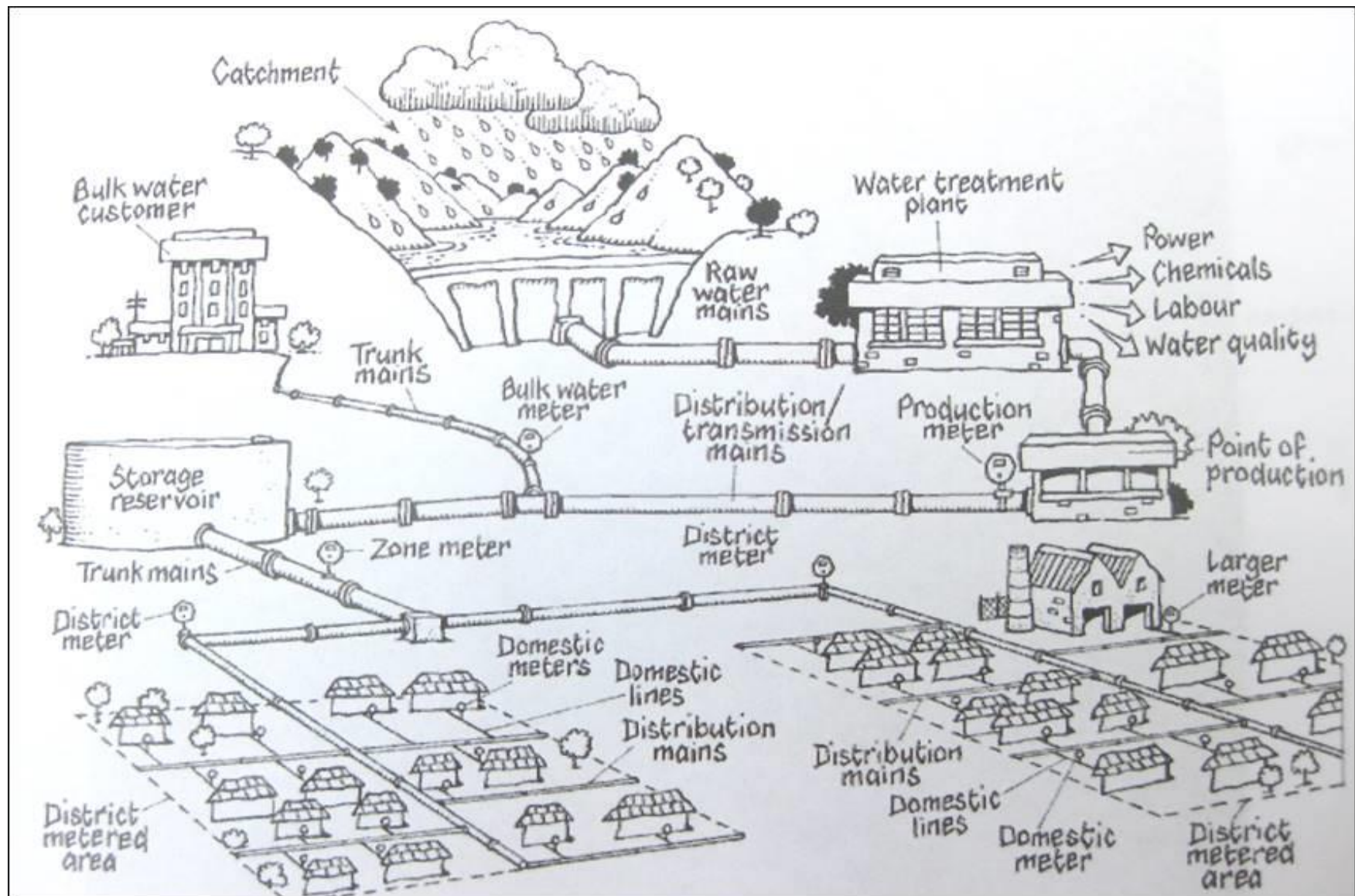

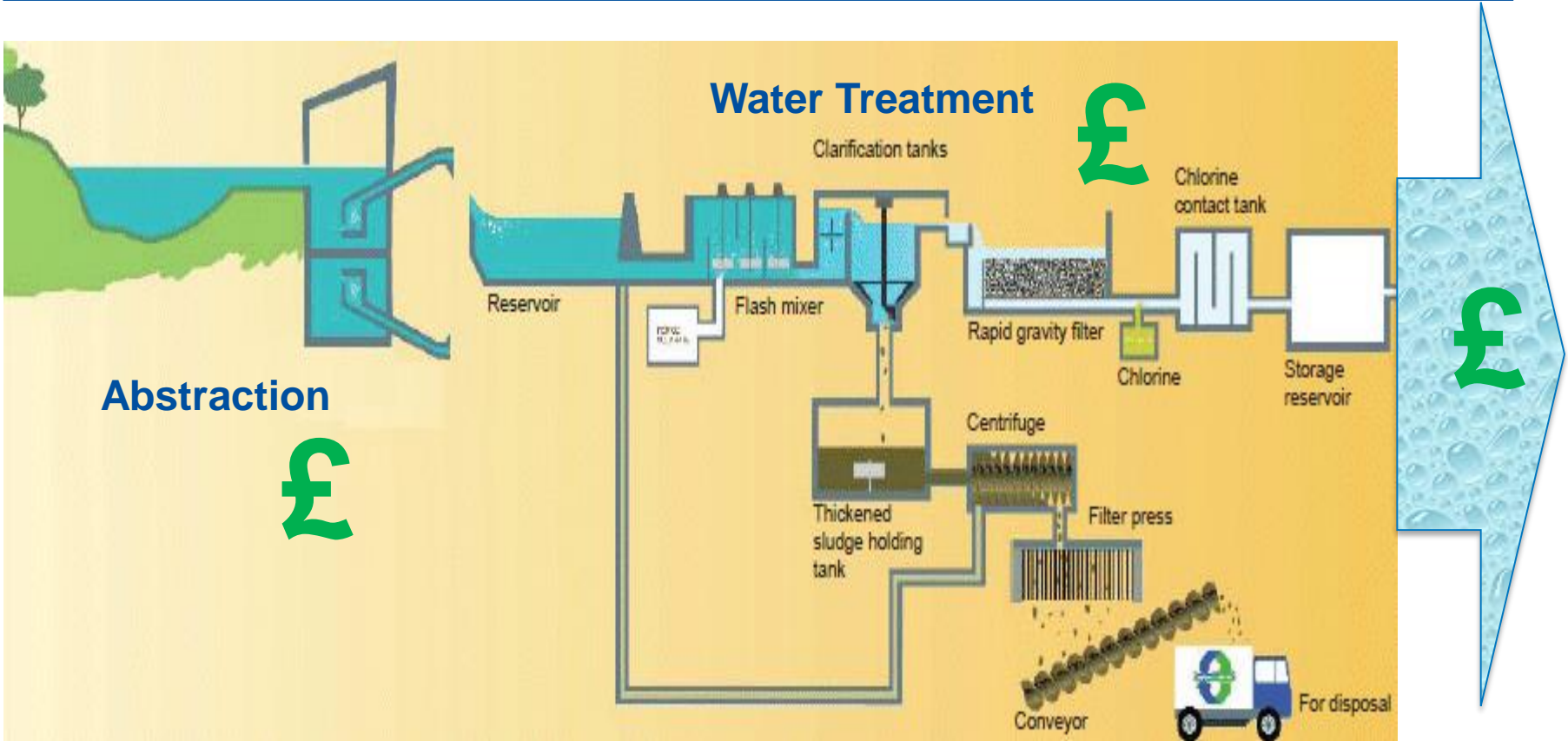

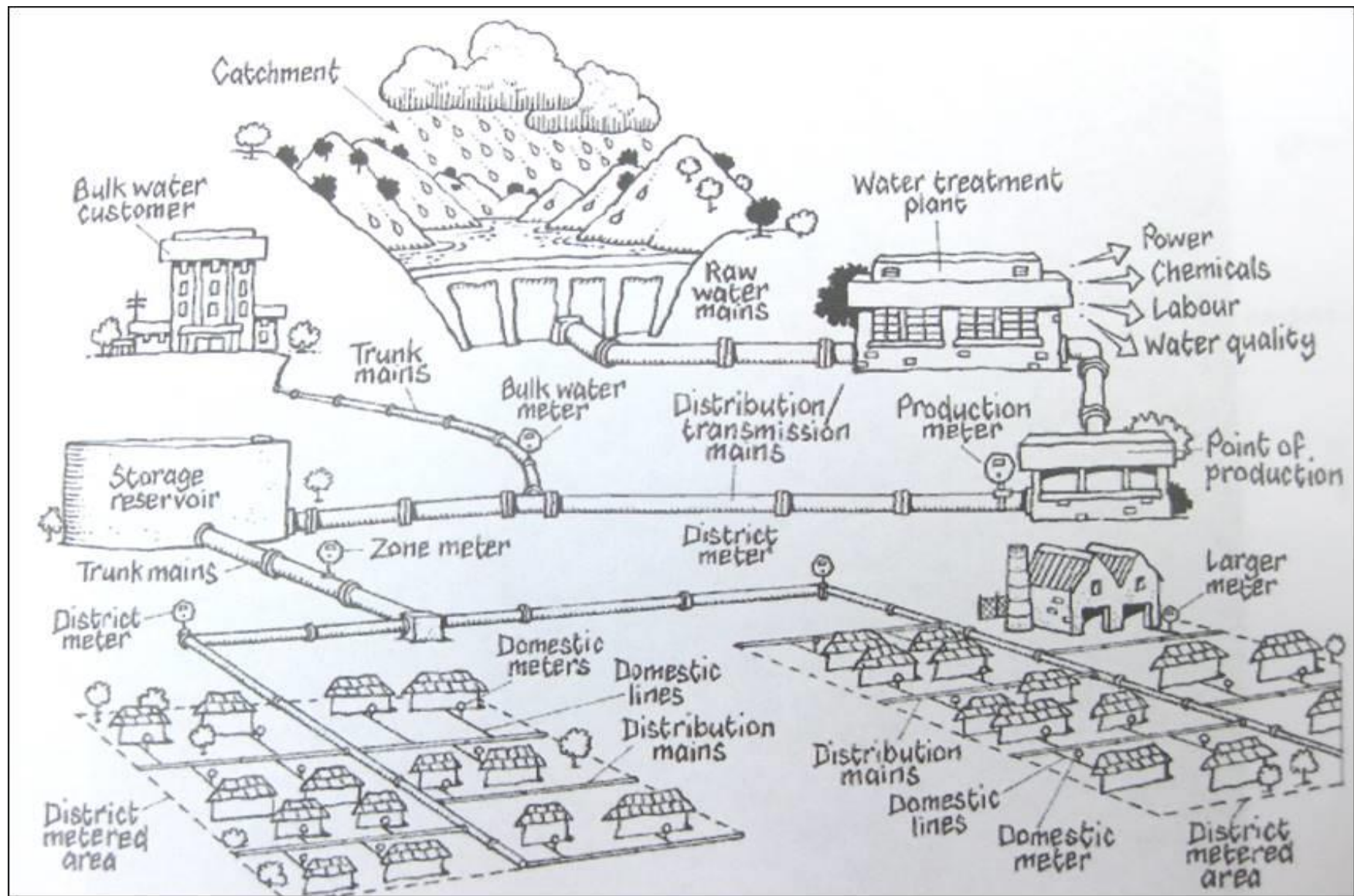

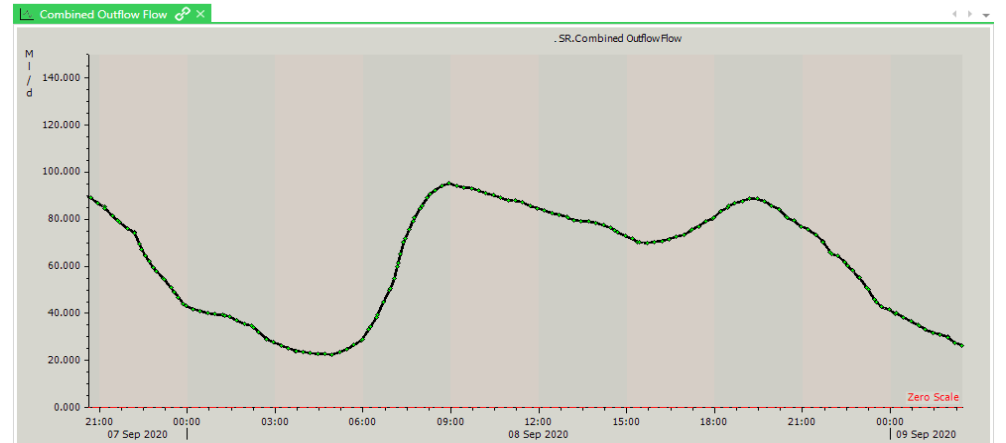
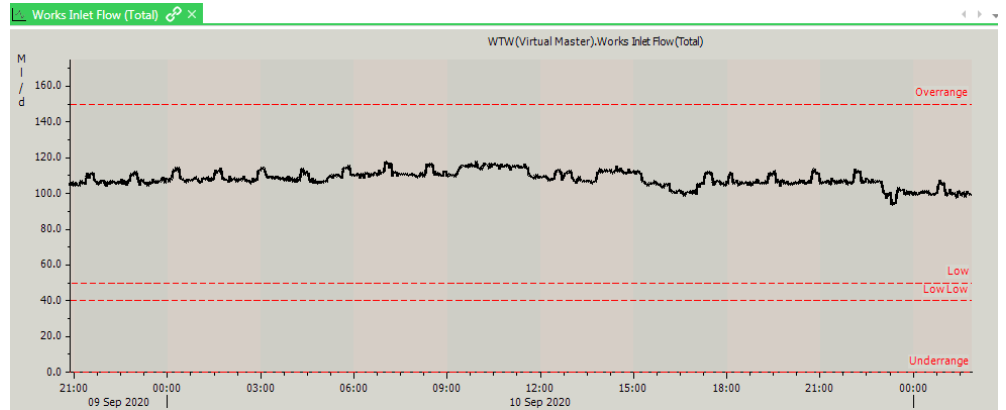
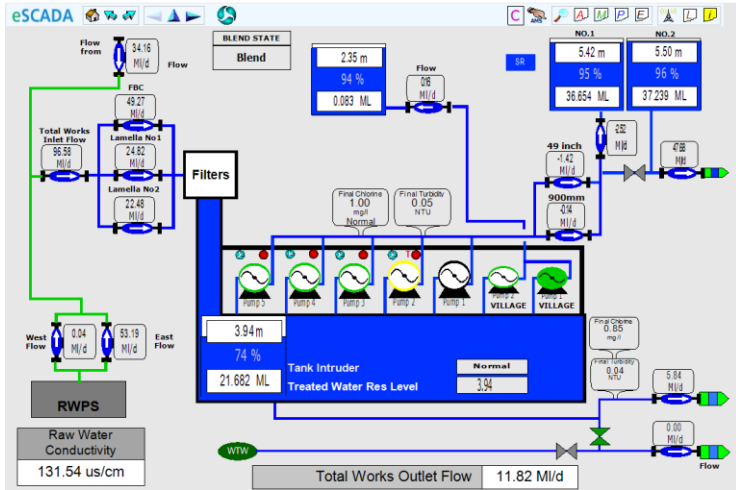

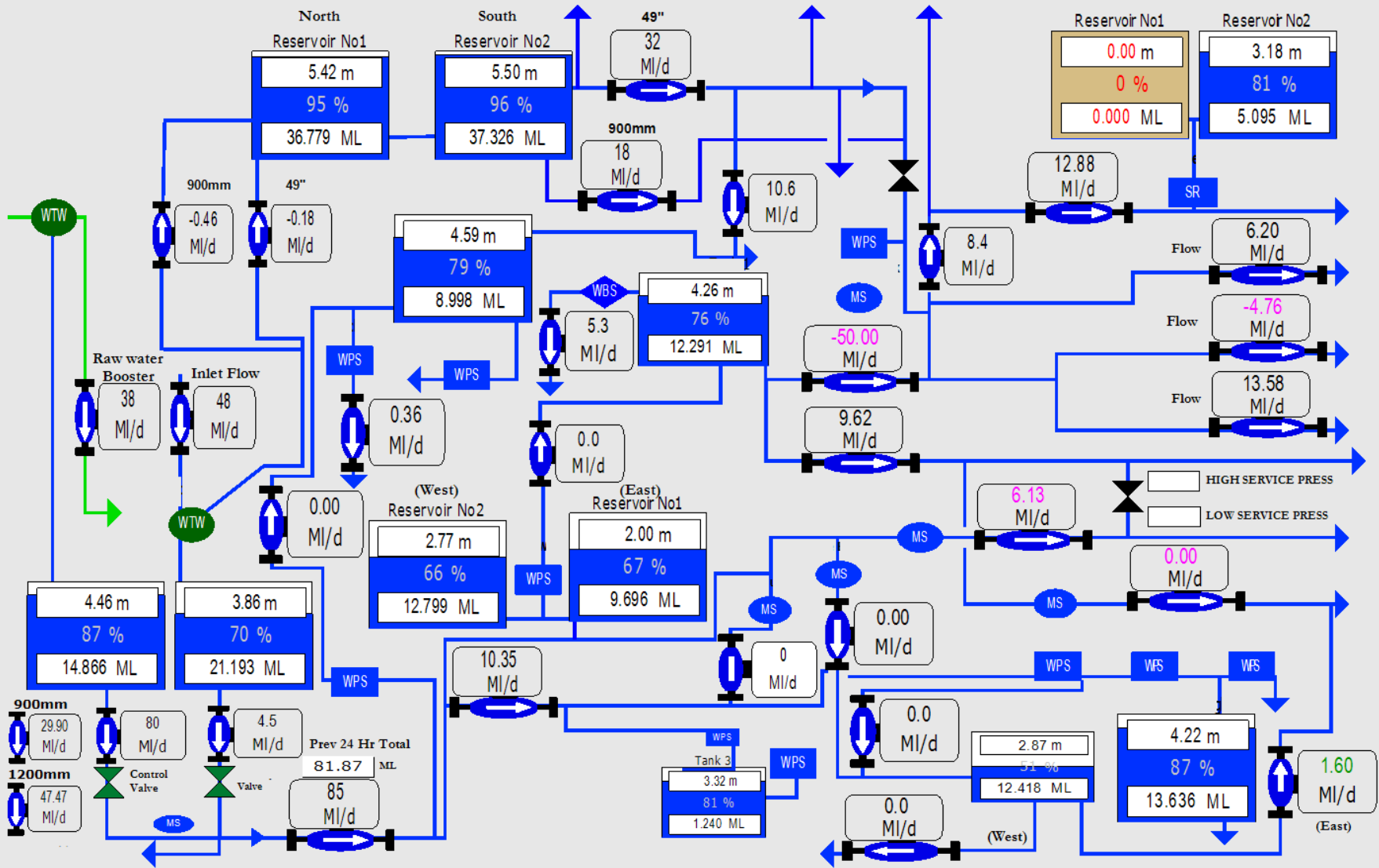

NETWORK ANALYSIS, COORDINATION & OPTIMISATION

Production Planning

- Performance against plan

Network Investment, Coordination & Planning

- Process development, delivery and promotion

Incident & Event Management, Preparation & Support

- standby and escalation

Network Resilience & Growth Investment Analysis

Performance Commitments

VISIBLE LEAKS
LEAKAGE NORTH
LEAKAGE SOUTH
ITS > 3 HRS
1 < ITS < 3 HRS
ITS > 12 HRS
APPEARANCE
TASTE & SMELL
CRI
ERI
BURSTS
PCC
UPO
RESILIENCE TO 1/200 YEAR DROUGHT
DELIVERY OF SMART METERING PROGRAMME
DELIVERY OF LEAD PROGRAMME
DELIVERY OF RESILIENCE PROGRAMME
AIM

Water Directorate			
<p>Network Operations Maintaining the distribution of water</p>	<p>Water Quality Ensuring the quality of water</p>	<p>Water Supply Producing Water</p>	<p>Water Service Planning Controlling water from source to tap</p>

Customer	Information Services
Waste Water	Commercial
HR	Regulation & Assurance
Asset Management	Finance



[Home](#) > [Help](#) > [Saving water](#)

Saving water

Water in numbers:

- in the UK, the average person uses **150 litres of water a day**
- a shower can use around **49 litres of water a day**, and
- brushing your teeth with the tap on can waste **6 litres a minute**.

Wasting water is like pouring your money down the drain.

If you think not having a meter means you can use as much as you like, think again.

We're lucky here in the north of England, but clean water is not unlimited. We all need to think about how we use water, and what we can do to cut down our usage.

[Read our useful tips to find out how you can save water.](#)

